

ENGLISH Summary

SECTION 1	18		
1.1 INTRODUCTION	18	4.1.2 DRIVELINE WITH ADJUSTABLE PLATE CLUTCH	25
1.2 WARRANTY	18	4.1.3 WORK POSITION	26
1.2.1 WARRANTY EXCLUSIONS.....	19	4.2 HITCHING TO THE TRACTOR	26
1.3 DESCRIPTION OF THE MACHINE	19	4.3 TRANSPORT POSITION	26
1.3.1 DESCRIPTION.....	20	4.4 DURING WORK.....	27
1.3.2 USE.....	20	4.3.3 USEFUL TIPS	27
1.4 IDENTIFICATION	20	4.5 TOOLS.....	28
1.5 NOISE LEVEL.....	21	4.6 STOPPING THE MACHINE.....	28
1.6 TECHNICAL SPECIFICATIONS	21	4.6.1 PARKING.....	29
		4.6.2 ELIMINATING OF THE MACHINE	29
SECTION 2	21	SECTION 5	29
2.1 SAFETY NOTES.....	21	5.1 ROUTINE MAINTENANCE	29
2.2 SAFETY DECALS	21	5.2 LUBRICATION	30
2.3 SAFETY AND ACCIDENT PREVENTING RULES	22	5.2.1 RECOMMENDED LUBRICANTS	30
		5.2.2 AFTER THE FIRST 8 HOURS SERVICE	30
SECTION 3	24	5.2.3 EVERY 20 HOURS SERVICE.....	30
3.1 TRANSPORT AND HANDLING	24	5.2.4 EVERY 100 HOURS SERVICE.....	30
		5.2.5 EVERY 500 HOURS SERVICE.....	30
SECTION 4	24	5.3 PREPARING FOR STORAGE	31
4.1 BEFORE USE	24	5.4 SPARE PARTS	31
4.1.1 DRIVELINE	25		

SECTION 1

Description and Main features

1.1 INTRODUCTION

This manual contains all the information and indications considered necessary to know, correctly use and normally service “b103” rotary tiller (also called machine in the text) manufactured by **BREVIGLIERI SpA** of Nogara (VR) Italy, also called Manufacturer in the text. The information and indications do not give a full description of the various components or a detailed illustration of how they operate. However, the user will find everything he normally requires in order to safely use the machine and keep it in a serviceable condition. Failure to comply with the indications given in this manual, negligence during work, incorrect use of the machine and unauthorized modifications to the same may void the warranty supplied by the Manufacturer.

The Manufacturer therefore declines all and every liability for damage due to negligence and failure to comply with the instructions in this manual.

If repairs or overhauls of a complex nature are required, contact an authorized assistance center with specialized personnel or the actual Manufacturer who is at your complete disposal for prompt and accurate technical assistance and anything else that can ensure you get the best and most efficient performance from the machine.

This manual must be kept in a safe place, ready to hand for consultation throughout the entire life of the machine. Reference will solely be made to the Italian version of the instructions in the event of disputes.

Some of the illustrations in the manual may not exactly depict the machine in your possession: they are included for the sole purpose of explaining the operations that must be carried out.

1.2 WARRANTY

The Manufacturer guarantees brand new products for a period of 12 (twelve) months from the date of delivery. When the machine is delivered, make sure that both it and the accessories are complete and in a perfect condition. Complaints should be presented in writing within 8 (eight) days from receipt of the machine. The warranty merely covers the repair or replacement, free of charge, of those parts which, after thorough examination by the Manufacturer, are recognized as being defective (with the exclusion of tines). Expenses concerning replacement of lubricants, transport costs, customs duties and VAT remain at the purchaser's charge in any case. Replacement or repair of parts under guarantee shall in no case extend the warranty terms.

The Manufacturer will not accept returned goods without prior written authorization.

The purchaser shall only be able to exercise his rights in relation to the warranty when he has complied with the conditions governing warranty performance, as indicated in the supply contract.

1.2.1 WARRANTY EXCLUSIONS

(Besides the circumstances indicated in the supply contract) the warranty becomes void:

- When the damage can be ascribed to insufficient maintenance.
- When, following repairs made by the user without the Manufacturer's consent or owing to the installation of spurious spare parts, the machine has been subjected to changes and the damage is ascribable to these changes.
- When the machine has been hitched to tractors whose power rating exceeds the value given in the "Technical Specifications" table in this manual.
- When the user has failed to comply with the instructions in this manual. Damage deriving from negligence, carelessness, bad and improper use of the machine or incorrect manoeuvres by the operator are also excluded from the warranty. Removal of the safety devices with which the machine is equipped shall automatically void the warranty and relieve the Manufacturer from all relative liability. The warranty also becomes void if spurious spare parts are used.

Even when covered by the warranty, the machine must be returned **Carriage Free**.

1.3 DESCRIPTION OF THE MACHINE

The **b103** rotary tiller bears «CE» marking in compliance with the European Union standards described in directive 98/37/EC and successive modifications, as stated in the declaration of conformity with which each machine is equipped.

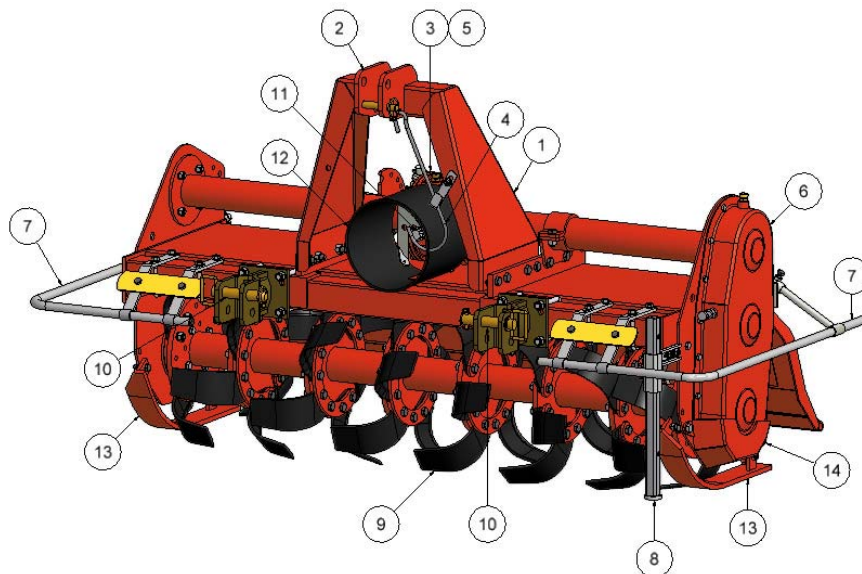



Fig. 1

1. Three-point hitch linkage
2. Upper 3-point hitch
3. Machine lifting point
4. Driveline support
5. Gearbox
6. Side transmission unit
7. Safety guards
8. Bearing stand
9. Bladed rotor
10. Lower 3-point hitch
11. Power take-off
12. Driveline shield
13. Work depth adjuster skid
14. Skid adjuster bolt
15. Identification plate

breviglieri S.p.A. 	
macchine agricole	
VIA A. LABRIOLA, 2 - 37054 NOGARÀ (Verona) ITALY	
MODELLO MODEL MODELE MODELL	VERSIONE VERSION TYPE VERSION
(A)	(B)
MATRICOLA REGISTRATION N° N° DI SERIE REGISTRATION NUMBER	MASSA Kg WEIGHT Kg POIDS Kg GEWICHT Kg
(C)	(D)
RIDUTTORI GEARBOX	
V.V. GEAR 1 P. 956 V.V. GEAR 2 P. 960	

15

DIMENSIONS

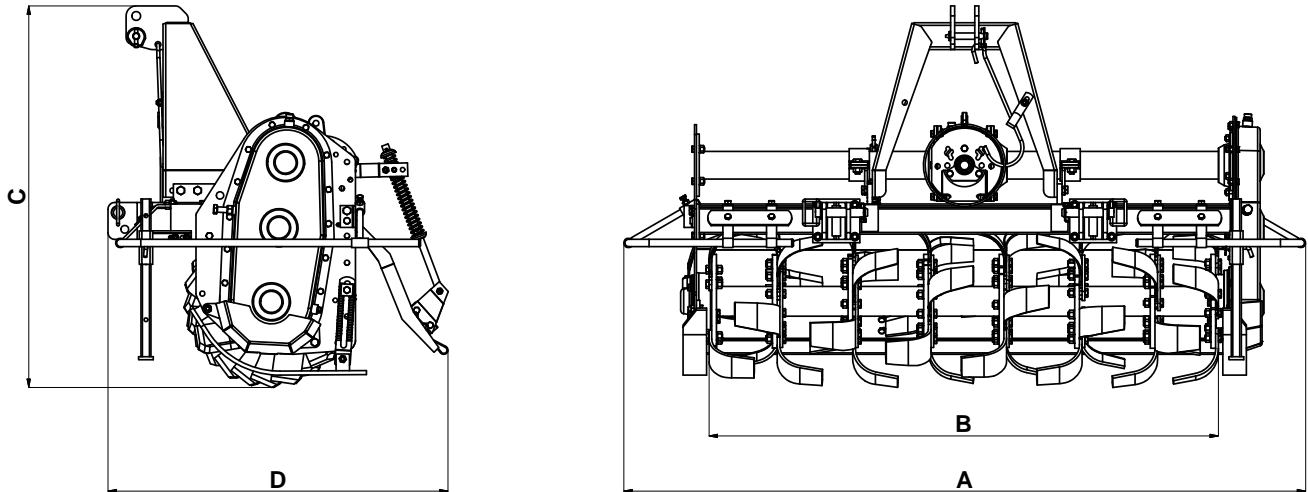

Fig.2

Model	A	B	C	D
b103 - 155	170	155	91,5	82,2
b103 - 185	200	185		
b103 - 205	220	205		
b103 - 230	245	230		
b103 - 250	265	250		

1.3.1 DESCRIPTION

The **b103** Rotary Tiller mainly comprises a metal framework with a central linkage and three-point hitches (1 Fig. 1), and a bladed rotor situated in the lower part (9 Fig. 1) driven by a gearbox installed at the side (6 Fig. 1). The power required to operate the machine is transmitted by the tractor via a driveline (with CE marking) which meshes with the gearbox/final drive unit in a central position (5 Fig. 1), and is subsequently transmitted to the gears by a drive shaft.

1.3.2 USE

The **b103** has solely been designed for use in agriculture in order to work and break up the soil. One single operator seated on the tractor is able to carry out the various tillage operations. Any other use of the machine differing from the explanations given in this manual relieves for Manufacturer from all and every liability for deriving damage to persons, animals or property.

1.4 IDENTIFICATION

Each machine is provided with an identification plate (15 Fig. 1) with the following data:

- «CE» marking
- Manufacturer's name and address
- A) Machine model
- B) Machine version
- C) Serial number
- D) Weight (in kg)
- E) Year of manufacture

The data on the identification plate of the machine should be copied into the last page of this manual and must always be stated when spare parts and/or assistance are required.

Standard machine supply includes:

- Driveline
- Operation and maintenance manual for the machine
- «CE» declaration of conformity

1.5 NOISE LEVEL

The noise level (overhead noise) has been measured in compliance with the current laws, with the following results:

- Acoustic pressure LpAm (A) dB 82
- Acoustic power LwA (A) dB 98



CAUTION

The operator is advised to wear adequate ear muffs as personal protective equipment to prevent damage to his hearing during daily work with the machine.

1.6 TECHNICAL SPECIFICATIONS

Mod.	Working width	Weight				Power requirement		N° cutting tools
		Hood	RD Ø477	RG Ø405	RP Ø406	CV	kW	
	cm	kg						
b103 - 155	155	590	670	720	750	50 - 70	37 - 52	36
b103 - 185	185	620	710	790	810	50 - 70	37 - 52	42
b103 - 205	205	650	750	820	870	60 - 75	44 - 55	48
b103 - 230	230	680	790	890	910	70 - 80	52 - 59	54
b103 - 250	250	710	840	920	970	75 - 100	55 - 74	60

SECTION 2

General safety regulations

2.1 SAFETY NOTES

The user must inform his personnel about the risks deriving from accidents, about the safety devices installed to safeguard the operator and about the general accident-preventing regulations established by the Directives and by the laws in force in the country where the machine is used. It is therefore essential for operators to carefully read this manual, particularly the safety notes, and to pay great attention to operations which could be particularly hazardous.

The Manufacturer declines all and every liability for failure to comply with the safety and prevention regulations given in this manual.



Pay attention to this symbol when it appears in the manual. It indicates a possible danger situation.

There are three danger levels:

- **DANGER:** This is the maximum level danger signal and warns that unless the described operations are carried out correctly, they will cause serious injuries, death or long term health hazards.
- **WARNING:** The «WARNING» signal warns that unless the described operations are carried out correctly, they could cause serious injuries, death or long term health hazards.
- **CAUTION:** This sign warns that unless the described operations are carried out correctly, they could cause damage to the machine and/or persons.

2.2 SAFETY DECALS

The machine has been designed and built in compliance with all possible safety standards able to safeguard those who work with it. Despite this, there may still be residue hazards which are signalled on the machine by decals. These decals (pictograms) are affixed to the machine and indicate the various situations of insecurity and danger in a brief form.

Keep the decals clean and immediately replace them if they detach or become damaged.

Carefully read the following descriptions and memorize the meanings of the safety decals.



Carefully read the instruction manual before beginning work.



Before proceeding with maintenance operations, stop the machine, lower it to the ground and consult the instruction manual.



Sharp objects could be thrown up by the machine. Keep at a safety distance.



Danger of lower limbs being cut off. Keep at a safety distance from the machine.



Danger of upper limbs being cut off. Do not remove the guards and keep well away from moving parts.



Danger of being caught up by the driveline. It is absolutely forbidden to get near the driveline when it is operating.



Danger of falling. It is absolutely forbidden to climb on to the machine.



Hitching points to lift the machine.



Personal protective equipment to safeguard against noise.

2.3 SAFETY AND ACCIDENT PREVENTING RULES

Carefully read the safety and accident-prevention rules before using the machine. Consult the Manufacturer if in doubt. The Manufacturer declines all and every liability for failure to comply with the safety and prevention regulations described below.

- Do not touch moving parts.
- Adjustments or work on the machine must only be carried out when the tractor engine is off and the tractor blocked.
- It is absolutely forbidden to transport persons or animals on the machine.
- It is absolutely forbidden to operate the tractor or have it operated, with the machine hitched, by persons who are not in possession of an adequate driving license, by inexperienced persons or by those whose psycho-physical conditions of health are not good.
- Comply with all the accident prevention measures recommended and described in this manual.
- When a machine is hitched to a tractor, the weights will be distributed differently on the axles. It is therefore advisable to add ballast at the front of the tractor in order to balance the weight on the axles.
- When hitched to the tractor, the machine can only be operated with the driveline complete with shields fixed by their chains. Keep well away from the spinning driveline.
- Before starting the tractor and machine, make sure that all the safety devices for transportation and use are in perfect conditions.
- Comply with the Highway Code regulations in force in your country when travelling on public roads.
- Do not exceed the maximum tolerated weight on the tractor axles.
- Become familiar with the controls and their functions before beginning work.
- Wear suitable clothing.
- Do not wear loose or flapping garments, scarves, necklaces or ties which could become caught up in moving parts. Wear protective garments such as goggles, gloves and protective footwear if required in the country where the machine is used or when working on particular stony ground.
- The machine must be hitched to a tractor with an adequate power rating.
- Pay the utmost attention when hitching and unhitching the machine to and from the tractor.
- Any accessories used for transportation purposes must be equipped with adequate signs and guards.

- Never ever leave the driver's seat whilst the tractor is operating.
- When driving round bends with and without the machine, take care of the centrifugal force exercised when the center of gravity is in a different position.
- Check the rpm rate before engaging the power take-off. Do not switch the 540 rpm rate with the 1000 rpm one.
- It is absolutely forbidden to linger within the range of action of the machine when this is operating.
- Before you get off the tractor, lower the machine hitched to the power lift unit, stop the tractor engine, engage the parking brake and remove the ignition key from the control panel.
- It is absolutely forbidden to get between the tractor and machine while the engine is running and the driveline engaged.
- Move the power lift control lever to the locked position before you hitch or unhitch the machine to or from the three-point linkage.
- The class of the machine's coupling pins must correspond to that of the power lift hitch.
- Take great care when you work near the lift links. This is a very dangerous area.
- It is absolutely forbidden to get between the tractor and the machine hitch in order to manoeuvre the lifting command from the outside.
- Fix the side lifting links with the relative chains and idlers during the transport phase.
- Set the control lever of the tractor's hydraulic lifting control in the locked position when driving on the roads with the machine raised.
- Only use the driveline recommended by the Manufacturer, with «CE» marking.
- Periodically check the driveline shield. It must always be in an optimum condition and securely fixed.
- Pay the utmost attention to the driveline guard, both during transport and work.
- The driveline must always be assembled and disassembled when the tractor engine is off.
- Make sure that the driveline is assembled on the tractor and machine PTO in the correct way.
- Prevent the shields from turning by means of the relative chains and always read the operation and maintenance manual supplied with the driveline.
- Make sure that there are no bystanders or animals in the vicinity before you engage the PTO.
- Do not engage the PTO when the engine is off.
- Disengage the PTO when the driveline is at an excessively wide angle (never more than 10 degrees, Fig. 3) and when it is not used.
- Only clean and grease the driveline when the PTO is disengaged, the engine off, the parking brake engaged and the ignition key removed from the tractor's ignition switch.
- Rest the driveline on its stand (4 Fig. 1) when not used.
- Prolonged use of the machine can cause the overdrive housing (5 Fig. 1) and certain parts of the hydraulic circuit to overheat. Do not touch these parts during and immediately after using the machine since they could cause burns.
- Do not carry out servicing or cleaning operations unless the PTO has been disengaged and the tractor engine turned off.
- Periodically check to make sure that the nuts and bolts are well torqued. Tighten them if necessary.
- Place adequate supports under the machine as a precaution when servicing or replacing the tines/blades with the machine raised.
- Before working on the cutting tools, detach the PTO, turn off the tractor engine, engage the parking brake and make sure that the tines are at a standstill.
- Use the recommended oils.
- Spare parts must comply with the requirements established by the Manufacturer. Only use genuine spare parts.
- The safety decals must always be clearly visible. They must be kept clean and replaced if they become illegible (new ones can be obtained from the Manufacturer).
- The instruction manual must be kept throughout the life of the machine.
- If the country in which the machine is used has noise prevention laws, adapt to these provisions by using the appropriate protections. The measured noise levels are given in section «1.5 Noise level».
- Comply with the laws in force in the country where the machine is used when it comes to using and disposing of the products used to clean and service the machine. Also comply with the instructions given by the manufacturer of such products.
- Comply with the anti-pollution laws in force in the country of use if the machine must be scrapped.

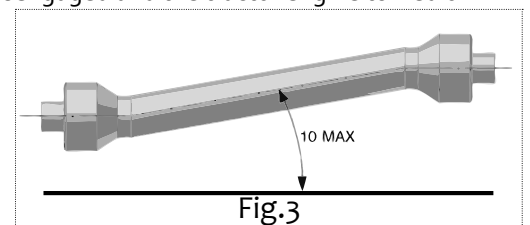

SECTION 3

Transport and handling

3.1 TRANSPORT AND HANDLING



CAUTION

If the machine, hitched to the tractor, must circulate on the public roads, comply with the Highway Code regulations in force in the country in which the machine itself is used.

The machine must be raised at least 40 cm from the ground for road transport.

If the machine must be transported over a long distance, it can be loaded on a truck or railway car. In this case, consult «1.6 Technical specifications» for the weight and dimensions. This will allow you to make sure that the machine can pass through tunnels or low constructions without difficulty. To lift the machine from the ground to the loading platform, use a crane with an adequate carrying capacity and hook up the machine from the relative lifting points indicated on the machine.

Loading with a crane: make sure that the carrying capacity of the crane is fit to lift the weight of the machine. The connecting points for lifting are clearly visible and are marked by stickers. Lift the machine with the utmost care and move it slowly without jolting on to the truck or railway car.



DANGER

The lifting and transporting operations can be very dangerous unless they are carried out with the greatest care: have all persons not directly involved in the lifting operations move well clear of the lifting area. Clear and delimit the zone to which the machine is to be transferred. Make sure that the available lifting means are fit for the purpose. Do not touch hanging loads and always keep at a safety distance from them. When transported, the loads must not be lifted more than 20 centimeters from the ground. Also make sure that the zone in which the operations take place is uncluttered and that there is a sufficient «escape route», i.e. a clear and safe zone to which the operators can quickly move if the load should fall.



CAUTION

The surface on to which the machine is to be loaded must be perfectly horizontal, to prevent the load from shifting.

Once the machine has been moved on to the truck or wagon, make sure that it remains blocked in position.

- Fix the machine firmly to the surface on which it rests by means of the pre-engineered points marked with the «hook» decal, using well tightened ropes or chains suited to its weight and able to prevent it from moving in any way.
- After having transported the machine to the desired site and before removing the elements that hold it in place, make sure that its position is unable to be of danger.
- Now remove the ropes and unload the machine from the means of transport in the same way as it was loaded.

SECTION 4

Instructions for use

4.1 BEFORE USE



WARNING

Before he sets the machine at work, the operator must have read and understood all parts of this manual and particularly

«Section 2» about safety.

Before beginning work, make sure that the machine is in order, that the lubricating oils are at the right level and that all parts subject to wear and deterioration are fully efficient. Also make sure that the guards are correctly positioned.



DANGER

Adjustments and operations required to prepare the machine for work must always be carried out with the machine off and blocked.

4.1.1 DRIVELINE



DANGER

The driveline is a mechanical component. When it is operating it can be a source of danger to the physical well-being of those who work with it. Take the greatest care when carrying out operations that involve the driveline. Carefully read the instruction manual supplied with the driveline. If you have doubts about the way it operates, if it is without its shields, worn or broken, replace it with a new driveline that possesses the same characteristics and bears the «CE» mark.



DANGER

Never modify or adapt the driveline in any way.

If the length must be adapted, work with the utmost care so as to keep the telescopic tubes coupled to the maximum extent. With the exception of length adaptation, it is forbidden to modify the driveline. If this is necessary, contact the Manufacturer. Take the greatest care when inserting the driveline. Make sure that it is well locked on both the tractor's PTO and on the machine. Also comply with the indications in the instruction manual supplied with each driveline. Make sure that the driveline shield, fastened with the relative chains, is free to turn without obstruction. Also check the guards on both the tractor and implement. If they are not in a perfect condition, they must be immediately replaced with new protections. It is very important for the protective guards to overlap the driveline shields by at least 5 cm on both sides.

When the driveline is fully extended, in all work conditions, the telescopic tubes must overlap to at least 1/3rd of their length (A Fig. 4).

When the driveline is fully inserted, the play must be at least 4 cm (B Fig. 4). Contact the Manufacturer's Technical Service if this is not possible.

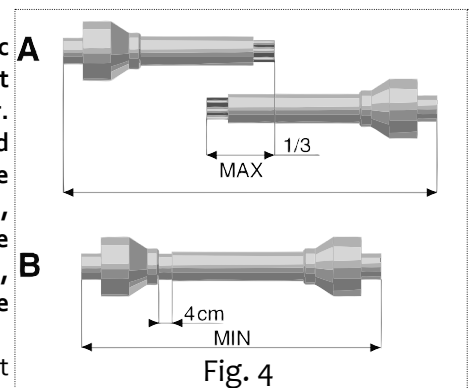

CAUTION

Before engaging the PTO, make sure that its rotation speed corresponds to the rate for which the machine has been designed.

4.1.2 DRIVELINE WITH ADJUSTABLE PLATE CLUTCH

The driveline has a safety clutch to protect the transmission components of the machine against stress and excessive overloads. The clutch is calibrated for medium-duty use. If it slips during work, all the nuts that hold the springs must be evenly tightened by half a turn and the operation of the device checked after about 200 meters of work. Repeat the operation if necessary. The clutch must be adjusted by unscrewing the nuts if it is blocked.



CAUTION

If the clutch still slips even when all the nuts have been tightened, the friction plates must be changed as they could be worn or because the springs have become slack. Never fully tighten the nuts as this eliminates the function of the springs and clutch itself, to the detriment of the transmission components.

4.1.3 WORK POSITION



DANGER

The operator must be seated in the driving seat of the tractor when the machine is working since only from that position is he able to act correctly. Before he leaves the driving seat, the operator must stop the machine, apply the parking brake and turn off the tractor engine.

4.2 HITCHING TO THE TRACTOR



DANGER

Hitching to the tractor could be a dangerous operation. Take great care and strictly comply with the instructions.

Proceed in the following way to hitch the machine to the tractor in the correct way:

- Make sure that you are using a tractor whose configuration suits the machine in question.
- Make sure that there are no objects, bystanders and/or animals in the immediate vicinity of the machine and that the PTO is disengaged.
- Make sure that the machine is in a stable, horizontal position, then back up the tractor towards the machine.
- Drive the tractor near to the implement with caution and adapt the height of the lift links to the height of the hitching pins.
- Move the power lift bars near and fit them on to the hitching pins. Now lock in place with the supplied split pins.
- Switch off the tractor engine.
- Connect the top link and adjust it so that the machine is on the flat.
- Lock the power lift bars with the relative chains and parallel idlers on the tractor. This must be done to prevent the machine from swinging sideways.
- Fit the driveline into the machine's power take-off and make sure that it is perfectly locked in the correct position.
- Make sure that the shield is free to turn. Fasten the shield with the relative chain. Remove the support from the driveline (4 Fig. 1) and fix it on the relative hook.
- Switch on the tractor engine, slightly lift the machine from the ground and raise the bearing stands.

4.3 TRANSPORT POSITION

The following expressions must be observed to ensure that the tractor-machine assembly is stable (Fig.5):

$$M \times s \leq 0,2T \times i + Z(d+i)$$

$M \leq 0,3T$ (prudential value)

$Z \geq \{[(M \times s) - (0,2T \times i)] / (d \times i)\}$ (for calculating the ballast)

where:

i = tractor's wheelbase

d = horizontal distance between the center of gravity of the front ballast and the tractor's front axle

s = horizontal distance between the center of gravity of the machine and the tractor's rear axle

T = weight of the tractor in running order

Z = ballast weight

M = weight of the machine

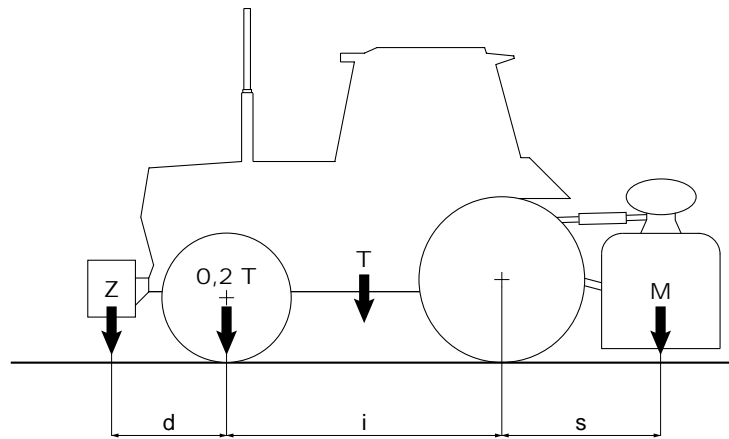

Fig. 5

4.4 DURING WORK

Proceed in the following way after you have correctly hitched the machine, sat down in the driver's seat of the tractor and started the tractor engine:

- Raise the machine about 10 cm from the ground so that the rotor does not touch the vegetation that needs to be cut
- Run the engine at a low rate and engage the PTO
- Gradually accelerate until the PTO is operating at full rate
- Engage the forward gear and start work with the PTO at full rate
- Gradually lower the machine until it rests on the ground. This allows it to adapt to the contours of the soil.



CAUTION

Do not depress the accelerator pedal in an imprudent way with the PTO engaged.

To break up the soil to the required degree, you must consider several factors, ex:

- The nature of the soil (medium consistency, sandy, clayey etc.)
- The working depth
- The ground speed of the tractor
- Optimum machine adjustment

For a better soil levelling and crumbling, the rotary tiller is equipped with a rear hood, with adjustable opening by means of a locking chain and on request by means of a spring rod.



WARNING

Adjust the hook by keeping it as opened as possible to obtain a better levelling thus avoiding dangerous throwing of the clods and stones as well as the hood itself



CAUTION

An excessive depth adjustment, in particular by means of the spring rod, means high efforts and early wear and tear.

A better soil crumbling can be obtained with a low tractor ground speed, the rear bar lowered and the blade-holder rotor spinning at 200 rpm. Besides holding back the clods already broken up by the blades, the rear bar also gives a well-levelled and uniform surface after the soil has been worked. When the rear bar is raised, the clods are no longer broken up and the soil is no longer levelled.

4.3.3 USEFUL TIPS

Here are a few useful suggestions on how to resolve some of the problems that may occur during work.

Cut plants shredded to much

- Slightly lift the cutter from the ground, adjusting the height with the wheels (the blades of the cutter must not touch the ground).
- Increase the ground speed.

Cut plants not shredded enough

- Slightly lower the machine towards the ground.
- Reduce the ground speed.
- Do not work in soil that is too wet.

Rotor clogged

- Soil too wet to work.
- Raise the machine from the ground.
- Reduce the ground speed.
- Do not work where the grass is too tall. If necessary, remove any material that has built up at the sides of the rotor to prevent overheating.

The machine jolts over the ground or vibrates

- Foreign bodies locked between the knives.
- Knives incorrectly mounted without the helical arrangement or with edges that dig into the ground.
- Worn or broken knives.
- Rotor misshapen owing to blows received during work from foreign bodies in the central part.

Other faults

- The machine fails to work evenly along its width, shredding either too much or too little on one side, for example on the right: shorten the right link.

Work on hilly ground

It is advisable to proceed «upwards» in the direction of the slope. Particular attention should be paid since, owing to the nature of the ground, the stability of the tractor could be compromised or it could slip sideways.

Winter periods

It is inadvisable to work with the machine during cold periods, when the temperature drops below 0°C (zero degrees centigrade), because the tines become sensibly more fragile. Moreover, when the weather is cold, the machine must be allowed to idle for a few minutes with the PTO at half rate so as to allow the lubricants and transmission components to warm up.

4.5 TOOLS

The knives with which the machine is equipped are suitable for work with soil/plants of normal conformation. Check their condition each day to make sure they are not worn. If they should accidentally bend (or break) during work, they must be immediately replaced and mounted in the identical position.



DANGER

Tool replacement is a dangerous operation.

Proceed in the following way to replace the tools:

- Park the tractor on a flat surface with the machine hitched, then raise the machine with the power lift
- Insert two strong bearing stands at the sides of the machine to protect yourself should it fall
- Lower the machine on to the stands, turn off the tractor engine and apply the parking brake

4.6 STOPPING THE MACHINE

At the end of the job, the operator must:

- Disengage the tractor PTO
- Lower the machine to the ground
- Stop the tractor and engage the parking brake
- Make sure that all parts of the machine have come to a standstill

Only after the above mentioned operations have been carried out may the operator leave the tractor unattended.

4.6.1 PARKING

To park the machine and unhitch it from the tractor, the operator must:

- Make sure that no one is standing or crossing the place where the machine will be parked
- Make sure that the place in which the machine is to be parked is suitable, flat and uncluttered
- Drive to the area where the machine is to be unhitched
- Brake the tractor
- Lower the bearing stands
- Completely lower the machine to the ground
- Stop the tractor and engage the parking brake
- Disconnect the quick couplings
- Remove the driveline from the tractor's PTO and rest it on its bracket
- Disconnect the top link rod
- Disconnect the power lift links
- Switch on the tractor engine and move away



WARNING

The place in which the machine is parked must be:

- Dry
- Sheltered from adverse weather conditions
- Guarded or locked up to prevent the machine from being accessed by animals, children or persons who are not trained to use it



CAUTION

If the machine is to remain idle for a long period of time, lubricate the parts subject to wear and store it in a dry, sheltered place, covered with a plastic sheet. This will ensure that the machine is in an ideal condition when required again.

4.6.2 ELIMINATING OF THE MACHINE

At the end of the operating life of the machine (or when it becomes obsolete), before carrying it in an authorized center, to make sure that not there is oil in multiplying or in the hydraulic system (incase present), to the aim to avoid highly polluting dispersions for the atmosphere. Is necessary to inquire itself near the competent local authorities by the procedure to follow, always in the respect of the national laws.

SECTION 5

Maintenance

5.1 ROUTINE MAINTENANCE

The various routine maintenance operations are described below. Remember that lower running costs and long machine life depend on continual compliance with these instructions.



WARNING

Before proceeding with any operation, make sure that the machine is parked on a flat surface. Prevent it from moving by placing chocks under the wheels.

Servicing, adjusting and the operations required to prepare the machine for work must be carried out with the tractor and the driveline detached from the machine.

The servicing frequencies indicated in this manual are indicative and refer to normal conditions of use. They may therefore vary

depending on the type of service, whether the environment is dirty or not, seasonal factors, etc.
The servicing operations must obviously be carried out more frequently in heavier duty service conditions.



CAUTION

Before injecting lubricating grease into the grease nipples, carefully clean the unions to prevent mud, dust or foreign bodies from mixing with the grease as this would reduce or even annul its lubricating effects.

Injection into the greasing points of a large quantity of grease at high pressure can damage the bearing protection.

This operation must therefore be carried out with due care.
Lubricate and grease all the required points.
Use oil of the recommended type for topping up and changes.



DANGER

Keep all lubricants well away from children's reach.
Carefully read the warnings and precautions on the lubricant containers.
The operator should thoroughly wash himself after using lubricants.
Dispose of used oil in compliance with the anti-pollution laws.

5.2 LUBRICATION

Lubrication of any machine with parts that turn and/or rub together is a vitally important task for the life and functionality of the actual machine itself. Lubrication must therefore be carried out systematically and at the required intervals. The frequencies given refer to machine use in a normal environment. If this machine is used in heavier duty conditions, it must naturally be lubricated more frequently.

5.2.1 RECOMMENDED LUBRICANTS

- It is advisable to lubricate the overdrive with: SAE 85W/140 OIL, complying with API-GL5/MIL-L-2105C specifications.
- For all greasing points, the Manufacturer recommends: LITHIUM GREASE.

When servicing the driveline, strictly comply with the instructions given by the driveline Manufacturer, in the specific operation and maintenance manual with which each driveline is equipped.

5.2.2 AFTER THE FIRST 8 HOURS SERVICE

Each new machine must be checked after the first 8 hours service. Proceed in the following way:

- Check the general condition of the machine
- Make sure that all the screws are well tightened
- Check the cutting tools for wear and make sure that the bolts that fasten them are well tightened
- Check the level of the lubricants

5.2.3 EVERY 20 HOURS SERVICE

- Make sure that the screws that fix the cutting tools are well tightened
- Grease the driveline

5.2.4 EVERY 100 HOURS SERVICE

Check the level of the oil in the overdrive housing. If necessary, top it up through the plug on the top of the gearbox.

5.2.5 EVERY 500 HOURS SERVICE

Change the oil in the overdrive housing after every 500 hours service or at least once a year.

5.3 PREPARING FOR STORAGE

Proceed with the following operations at the end of the season or if the machine is to remain idle for a long period of time:

- Wash all fertilizers and chemical products from the machine and dry it
- Carefully check the machine and replace any damaged or worn parts
- Fully tighten all the screws and bolts, particularly the ones that fix the tines
- Thoroughly grease the machine and then cover it with a tarpaulin and store it in a dry place. If these operations are carried out with care, it will be all to the user's advantage as the machine will be in optimum conditions when needed again.

If these operations are carried out with care, it will be all to the user's advantage as the machine will be in optimum conditions when needed again. If the machine must be dismantled, comply with the anti-pollution laws in force. Old lubricants must and the various components must be disposed of according to their different structures.

5.4 SPARE PARTS

All the parts forming the machine can be ordered from the Manufacturer, specifying:

- Machine model
- The serial number of the machine
- The year of manufacture
- The serial number of the required part (indicated in the spare parts catalogue), a description of the part and the required quantity
- The means of transport

Transport way: if this is not specified, the Manufacturer will dedicate particular care to the service but shall not be liable for delays in shipment due to unforeseen circumstances. The shipping costs are always at the consignee's charge. The goods travel at the purchaser's risk and peril even when sold carriage paid.

Remember that the Manufacturer is always at your disposal for any assistance and/or spare parts you may required.